

## DESCRIPTION

PT6959 is an LED Controller driven on a 1/4 to 1/7 duty factor. Fourteen to eleven segment output lines, 4 to 7 grid output lines, one display memory, control circuit are all incorporated into a single chip to build a highly reliable peripheral device for a single chip microcomputer. Serial data is fed to PT6959 via a three-line serial interface. Housed in a 28-pin SO Package, PT6959's pin assignments and application circuit are optimized for easy PCB Layout and cost saving advantages.

## FEATURES

- CMOS Technology
- Low Power Consumption
- 8-Step Dimming Circuitry
- Serial Interface for Clock, Data Input, Strobe Pins
- Available in 28-pin, SO Package

## APPLICATION

- Micro-computer Peripheral Device

**PIN CONFIGURATION**

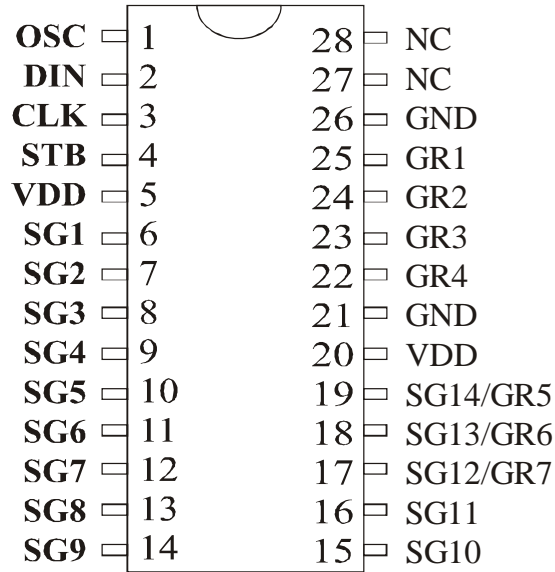

LED Driver IC

**PT6959**

**APPLICATION CIRCUIT**

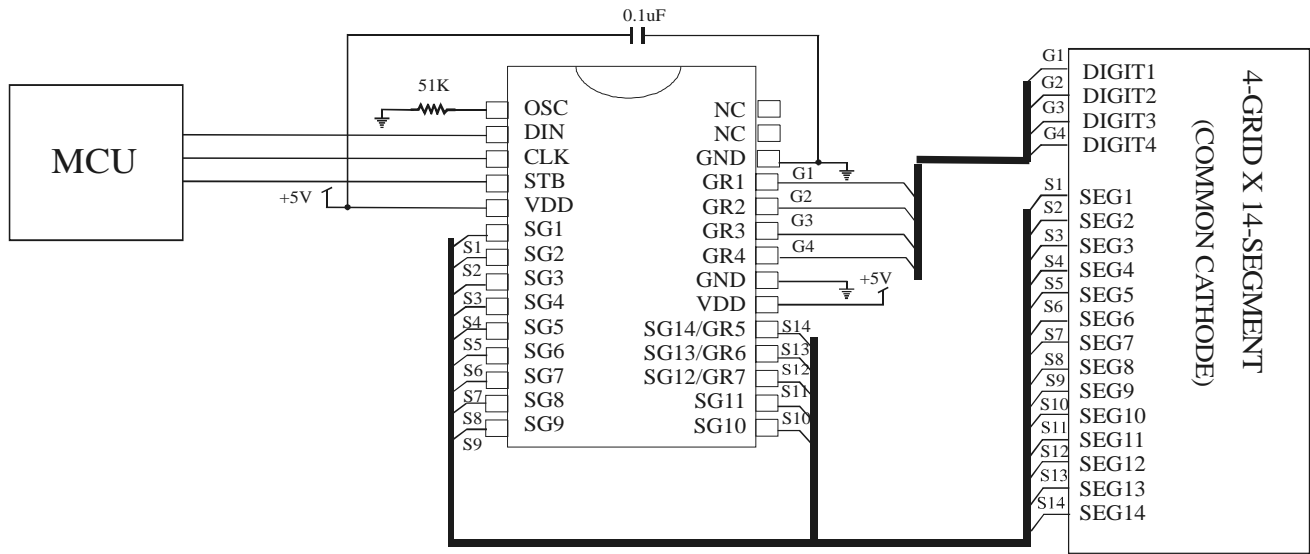

Note: The capacitor (0.1uF) connected between the GND and VDD Pins must be located as near as possible to the PT6959 chip.

COMMON CATHODE TYPE LED PANEL:

